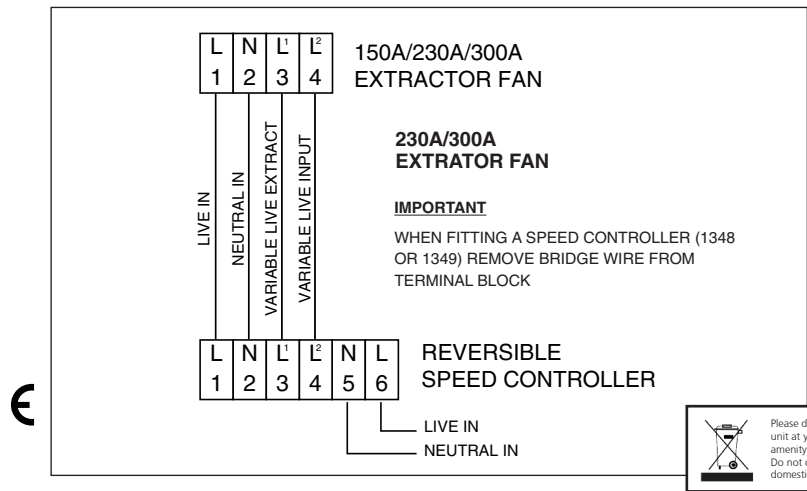
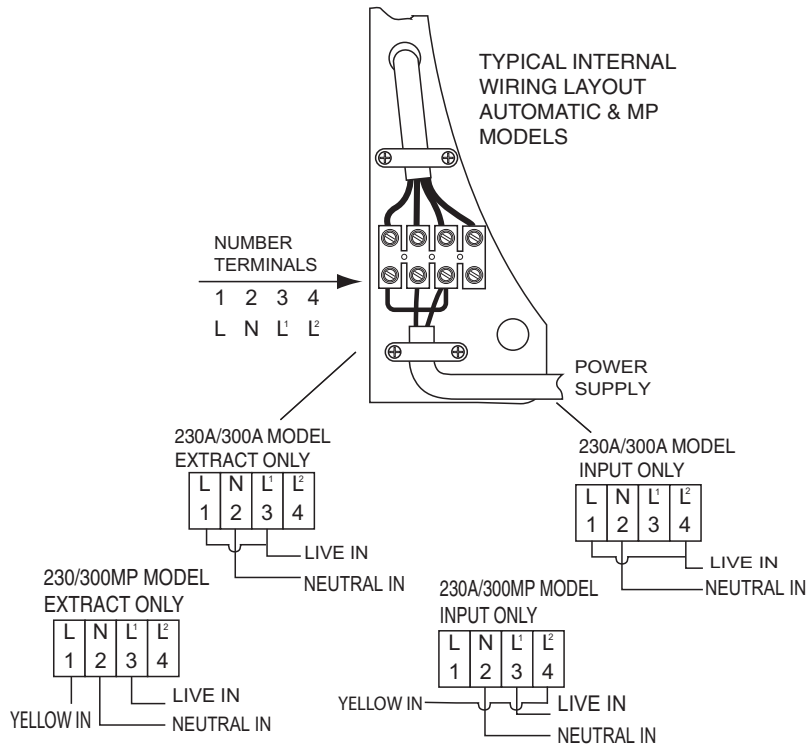

**DIAGRAM 5**

*Electrical Connections* **WIRING FOR 230/300 SERIES**



# Commerical Series

## Installation Instructions for the Commerical Series 150mm/6" 230mm/9" 300mm/12"

### Window/Wall Fans

**Installation in a Window**

- 1 Cut the following hole size in the glass.

MODEL	HOLE SIZE
150 Series	184 mm Ø 7 1/4"
230 Series	260 mm Ø 10 1/4"
300 Series	320 mm Ø 12 1/2"

This is best cut by a qualified glazier, alternatively, measure your window and get a new piece of glass with a pre-cut hole from your glass merchant and replace.

- 2 Remove external grille by gently levering the top out with two small screwdrivers and remove the posidrive screws and separate the two halves. (See Diagram 1 & 2.)

Hold the fan in position over the hole on the inside of the window and then refit the posidrive screws from the outside. Caution DO NOT overtighten these screws as it is possible that you might crack the glass. Then replace the external grille.

**Electrical Connections**

- 3 A double pole fused spur, having a contact separation of at least 3mm in all poles must be used and fitted with a 3 amp fuse, and must be sited outside any room containing a shower or fixed bath. They must not be accessible to a person using either the shower or bath.

*Note:* All wiring must be fixed securely and the cable to the fan should be minimum of 1mm<sup>2</sup> in section. All wiring must comply with current IEE Regulations. All installations must be supervised by a qualified electrician

**Through Wall & Ceiling Fitting**

- 4 Cut the following hole size through the wall.

MODEL	HOLE SIZE
150 Series	173mm Ø 6 3/4" use wall fixing kit
230 Series	255mm Ø 10" use wall fixing kit
300 Series	320mm Ø 12 1/2" use wall fixing kit

Fit the aluminium flexible duct (supplied with the wall fixing kit available separately) making sure that there is a slight tilt to the outside in case any water gets in through the external grille, so that it will not run into the room. Then make good around the duct.

- 5 Remove the rear grille and casing as described in Paragraph 2. Separate the external grille and remove the two hole plugs at the top and bottom of the grille chassis. Hold against the outside wall directly over the duct and drill and plug the fixing holes. Screw the grille chassis against the outside wall directly over the duct and drill and plug the fixing holes. Screw the grill chassis to the wall and refit the grille. It is important to make sure that the two fixing holes are one above the other to allow the lugs on the grille to fit properly into their slots right way up.

6 Remove the front grill by removing the 2 fixing screws which secure the front grille assembly to the main chassis.

Hold the body over the hole, first ensuring that the fan is level then mark four of the slot fixing holes available (one in each corner). Drill and plug these holes. Screw the fan to the wall and refit the front grille and replace screw caps.

7 Make the electrical connection as described in Paragraph 3.

All wiring must comply with current IEE regulations. If in doubt contact a qualified electrician.

*Note:* Fan must be fitted a minimum of 2.3 metres from the floor.

Do not install within a shower cubicle or anywhere where there is a high risk of the fan being sprayed with water.

8 Ratings as marked on fan label. T. Max 40°C.

9 To change the airflow direction remove link from Terminal 1 in the plug and connect into Terminal 2.

**Important.**

**Switch off mains supply before making any electrical connections.**

**The appliance is not intended for use by young children or infirm persons without supervision. Young children should be supervised to ensure that they do not play with the appliance.**

**Fan should be installed by fixed wiring only. A flexible cord should not be used.**

**Switch off mains supply before making any electrical connections.**

**All installations should be supervised by a qualified electrician.**

**Precautions must be taken to avoid the back-flow of gases into the room from the open**

**DIAGRAM 1**

*External Grille*

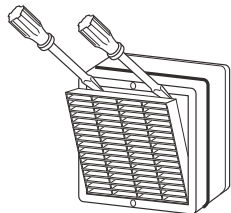

**DIAGRAM 2**

*Rear of Fan with Grille Removed*

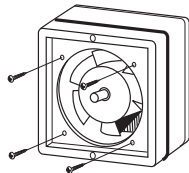

**DIAGRAM 3**

*Exploded View*

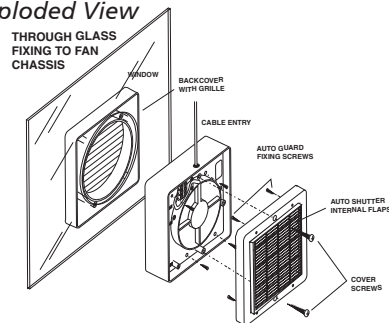

**DIAGRAM 4**

*Through Wall/Ceiling Fixing*

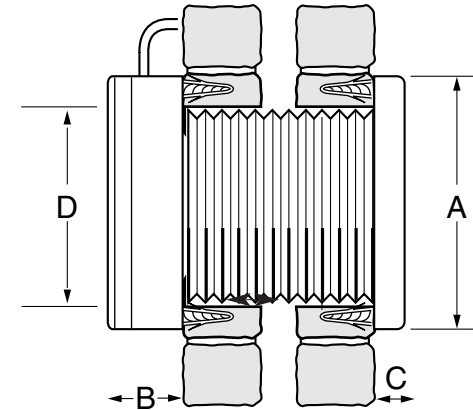

MODEL	WINDOW FAN				WALL FAN			
	A	B	C	D Hole Size	A	B	C	D Hole Size
150MP/150A	205mm	105mm	25mm	184 mm Ø 7 1/4"	205mm	67mm	23mm	173mm Ø 6 1/4"
230MP/230A	286mm	125mm	25mm	260 mm Ø 10 1/4"	286mm	75mm	25mm	255mm Ø 10"
300MP/300A	362mm	145mm	25mm	320 mm Ø 12 1/2"	362mm	81mm	29mm	320mm Ø 12 1/2"

**DIAGRAM 5**

*Dimensions*

*Through Window Fixing*

