

INSTALLATION INSTRUCTIONS

INSTALLATION INSTRUCTIONS FOR 100 / 120 / 150 mm MIXFLO FANS

Switch off mains supply before making any electrical connections.

Installation must be supervised by a qualified electrician.

This appliance can be used by children aged from 8 years and above and persons with reduced physical, sensory and mental capabilities or lack of experience and knowledge if they have been given supervision or instruction concerning the use of the appliance in a safe way and understand the hazards involved.

Children shall not play with the appliance.

Cleaning and user maintenance shall not be made by children without supervision.

Precautions must be taken to avoid the back-flow of gases into the room from the open flue of gas or other open-fire appliances when mounted in outside windows or walls.

Fan must be disconnected from electrical power before any maintenance is carried out.

Location

1. When installing this fan's ducting through an external wall, an external wall grille must be fitted at all times.
2. This fan should be fitted to ducting with a minimum duct length of at least 500 millimetres both sides of the fan.
3. Where ducted fans are used to handle moisture-laden air, such as a bathroom, a condensation trap should be fitted in any vertical exhaust ducts.
4. When using flexible ducting, ensure it is pulled taut. All ducting should be angled towards the external grille.
5. Ducting passing through cold voids should be insulated.
6. If the fan and duct extract grille is installed in a room containing a fuel burning appliance, the installer must ensure that the air replacement is adequate for both the fan and the fuel burning appliance.

Wiring

1. Switch off mains supply before making electrical connections. If in any doubt contact a qualified electrician.
2. These units are for fixed wiring only. A flexible cord must not be used. All wiring must be fixed securely and the cable to the fan should be a minimum of 1mm² in section. All wiring must comply with current I.E.E. Regulations or local regulations if outside the UK.
3. A double pole fused spur having contact separation of at least 3mm in all poles must be used and fitted with a 3A fuse.
4. This fan is double insulated and does not require an earth connection.
5. The fan should not be accessible to a person using either the shower or the bath.

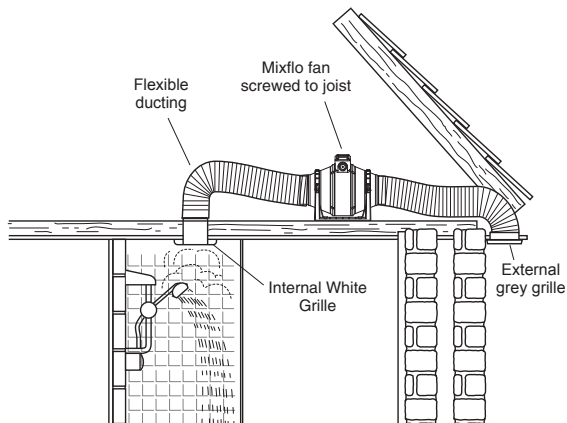

N.B Make sure that once the extractor is installed there is no accidental access to the moving parts.

Electrical Connections

1. The extractor fan must be connected to a single phase mains network, 220 - 240VAC.
2. The installation must have an omnipolar switch with a contact separation of at least 3mm. The circuit must be protected by either a 3 Amp fuse or suitable 3A MCB.
3. Earthing is not required as this extractor is a class II insulated appliance.
4. The extractor must be connected permanently to a fixed installation cable secured in fixed channelling. (Flex of two conductor wires of minimum section 1mm^2 and maximum 1.5mm^2)

To make the Electrical Connections

1. Loosen the 4 screws (A) and take off the connection cover
2. Perforate the flex holder (B) to allow the power supply wires to pass through.
3. Make the connections as indicated on the next page.

Body can be rotated to accomodate tight spaces.

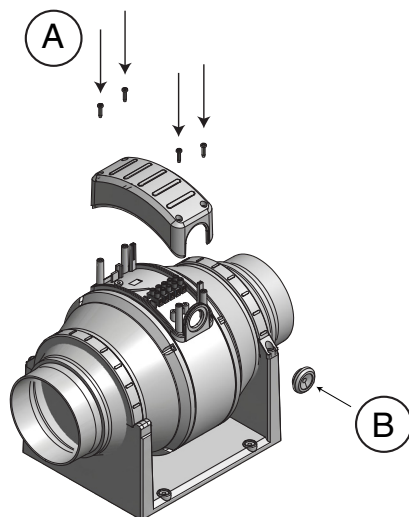
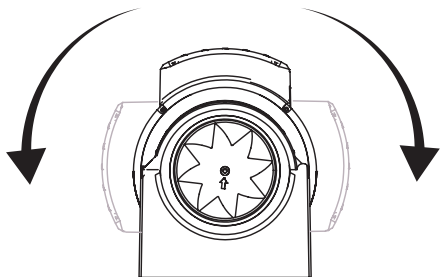

TIMER MODELS - LIVE, NEUTRAL AND SWITCHED LIVE

TO ADJUST OVER-RUN TIME - TIMER MODELS ONLY

USE A SMALL SCREWDRIVER TO ROTATE THE ADJUSTER ANTI-CLOCKWISE TO REDUCE THE TIMING, CLOCKWISE TO INCREASE THE TIME

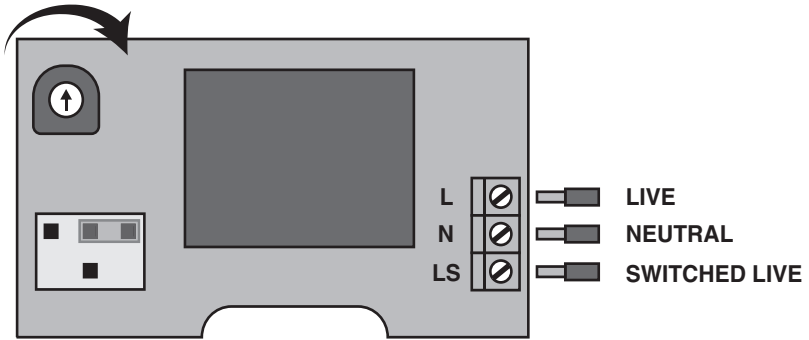

STANDARD MODELS - LIVE AND NEUTRAL ONLY

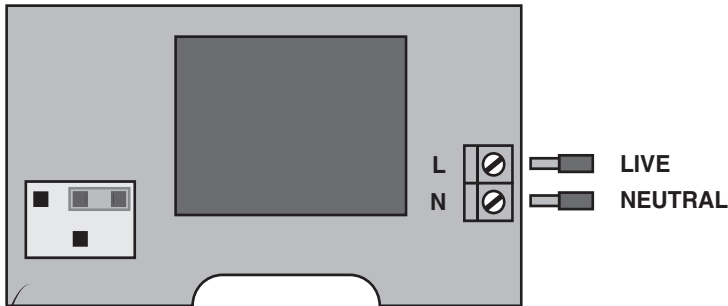

TO CHANGE SPEEDS

WARNING DISCONNECT FAN FROM THE MAINS SUPPLY BEFORE ADJUSTING:

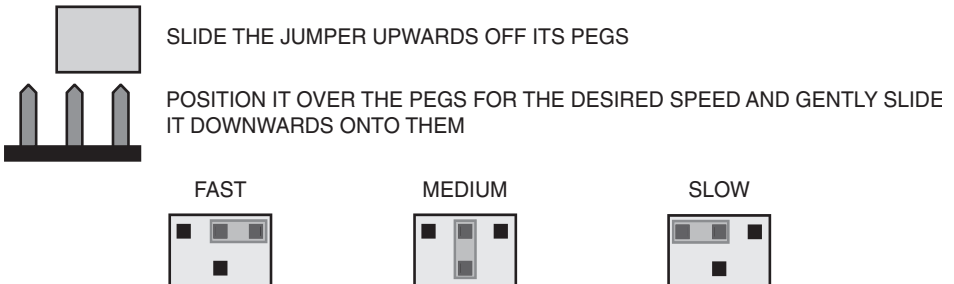

WARNING: IF USED IN CONJUNCTION WITH A SPEED CONTROLLER, THE FAN MUST BE SET TO HIGH SPEED ONLY

Maintenance and service

Switch off mains supply before making any electrical connections. If in any doubt contact a qualified electrician.

For any maintenance operation which is not simply cleaning the exterior of the extractor fan, the casing assembly must be taken out of its housing as indicated in point 1 of the installation instructions. Then the two reducer tubes (V) must be removed. (see Fig. 3)

To remove casing assembly:

1. Loosen 8 screws (x)
2. Gently separate reduce cones (V) from chassis.

The motor, fan and all the components must be regularly inspected to ensure that they are not dirty nor have suffered any damage. The frequency will depend on its operating conditions.

During the maintenance sessions remove any dirt collected on the fan blades and the internal parts of the frame to avoid any imbalance in operation which would lead to a reduction of the aerodynamic qualities and possible damage to the motor. Never submerge the appliance in water or in any liquid.

Do not use solvents to clean the appliance. The motor bearings need no maintenance.

RATING/SPECIFICATIONS

For all electrical power and IP ratings refer to the fan rating and wiring label.

Fig 3

