

150mm (6") In-line Fan Kit Range

Domestic Range

SF150A/ID150A



- The SF150 series of shower fans have been designed for the safe ventilation of larger shower rooms and bathrooms, or anywhere there is a possibility of contact with water.
- Any risk of an electric shock is removed as the fan is mounted remotely.
- Quiet and unobtrusive, the SF150 has a powerful extract rate of up to 220m³/hr 62 litres per second, depending on the length of ducting used.
- The fans are available separately or as In-line fan kits, which are supplied complete with fixing screws, plugs and straps to secure the duct onto the grilles and the fan unit, whilst the PVC ducting supplied is one 5m length 152mmØ.
- Suitable for use in changing rooms with showers, restaurants, bars and meeting rooms, schools and sports facilities, the SF150 has easy to follow instructions to make installation simple.
- The units are all manufactured using high impact ABS thermoplastics for strength and durability, including the internal and external grilles. The flexible ducting is made from PVC reinforced with steel wire.
- Power is provided by a single phase induction motor with pre-oiled bearings for a long, maintenance-free life.
- Designed to comply with the Building Regulations on Ventilation (F1).



Technical Details

Cat. No. Product type

In-line fan kits with PVC duct and wall grilles incorporating automatic in-line shutters

- SF150A** Standard model for remote switching
- SF150AT** Timer model adjustable (1-20 mins) In-line fans incorporating automatic in-line shutters

In-line fan only

- ID150A** Standard model for remote switching
- ID150AT** Timer model adjustable (1-20 mins)

Dimensions (mm)

PRODUCT	A	B	C	D
SF150A	152Ø	180	180	Up to 5m
ID150A	152Ø	180	180	

ID150 Series

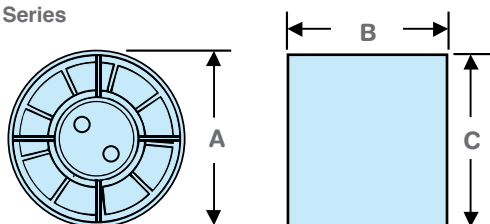

SF150/ID150 Series

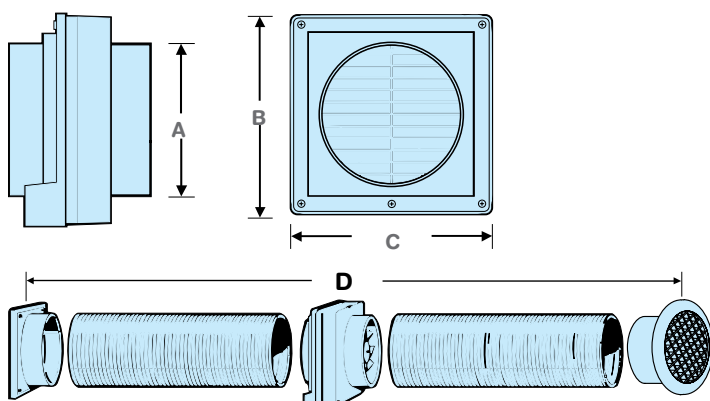

Performance

SF150/ID150 Up to 220m³/hr, 62 litres per second
 Maximum Fan performance stated, this can vary depending on the length of ducting used

Typical Installations

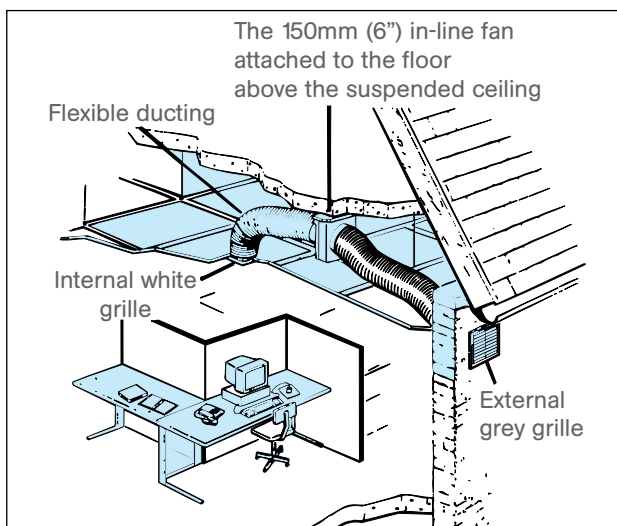
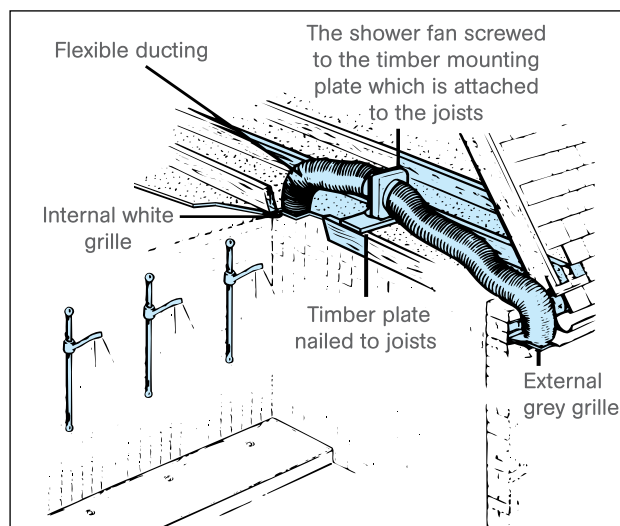

Packaging

SF150 In outers of 5 measuring 440mm x 393mm x 1083mm volume 1.87m³

ID150 In outers of 10 measuring 755mm x 229mm x 428mm volume 0.07m³

Installation

The 150mm shower fan is easy to install in the average loft/ceiling recess as, after the hole has been cut in the ceiling of the shower/room, all other work is continued outside the living area.

Electrical

220-240V~50Hz AC . Single phase consuming 25W on the SF150A automatic models. These fans are double insulated and do not require an earth. All wiring must comply with the current IEE regulations. A double pole isolating switch, having a contact separation of at least 3mm in all poles, must be used with a 3 amp fuse fitted.

Additional Data

- 150mm (6") Range
- Maximum pressure: 50 p.a.
- Fan speed: 2400 r.p.m.
- Sound volume: 40.0 dB(A)
- Maximum operating temperature: 40°C