

CFD200/220 In-line Centrifugal Fan Range

Domestic Range

CFD200/220 SCF200 & SLCFD



- Providing solutions for a wide range of domestic and commercial applications, the CFD200/220 in-line fan has been designed for use with suspended ceilings. A spring operated, non-return flap is built into the discharge spigot to prevent back draughts.
- Powerful, yet quiet and unobtrusive, the CFD200/220 units have extract rates of 110m³/hr 31 litres per second.
- The CFD series is suitable for a wide range of applications including bathrooms, toilets, shower rooms and utility rooms.
- The CFD series is fitted with backward curved centrifugal impellers for a large airflow against the high pressures caused by longer lengths of ducting and resistance by grilles.
- The CFD200/220 units are manufactured using high impact ABS thermoplastics for strength and durability, aesthetics and easy cleaning.
- Available with an integral mounting bracket. Designed to comply with the Building Regulations on Ventilation (F1).
- The CFD200/220 range is powered by a single phase induction motor with pre-oiled bearings for a long, maintenance-free life.
- The Shower Kit comprises of the CFD200 centrifugal in-line fan unit, 6 metres of PVC ducting and wall grilles.
- The Showerlite Kit comprises of the CFD200 centrifugal in-line fan unit, 6 metres of PVC ducting and wall grilles together with a chrome Showerlite fitting and transformer.
- The CFD220 has all the features of the CFD200 unit, but has the additional benefit of a 120mm outlet, thus making it suitable for 125mm (5") ducting systems.
- The SCF200 Series In-line Centrifugal Timer Kit now comes with a 3W LED lamp and uses 90% less power than a standard dichroic lamp.

Technical Details

Cat. No.	Product type
CFD200T	Timer model with bracket
CFD220T	Timer model with bracket
SCF200S	Standard model in-line fan kit (100mmØ)
SCF200T	Timer model in-line fan kit (100mmØ)
SLCFDTC	Timer model in-line Showerlite fan kit (100mmØ) Chrome
LEDSLCFDTCN	Timer model in-line fan kit (100mmØ) with a 3W Warm LED lamp and uses 90% less power than a standard dichroic lamp.
IWLEDSLCFDTCN	As above with a 3W Cool LED lamp

Dimensions

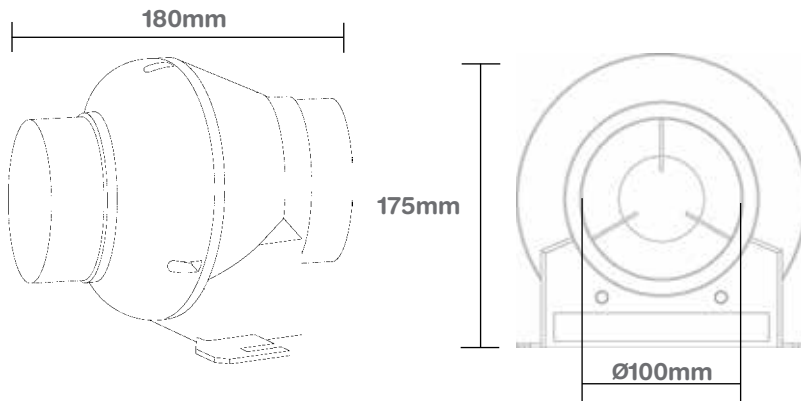

Performance Graph

CFD200 Range 110m³/hr, 31 litres per second

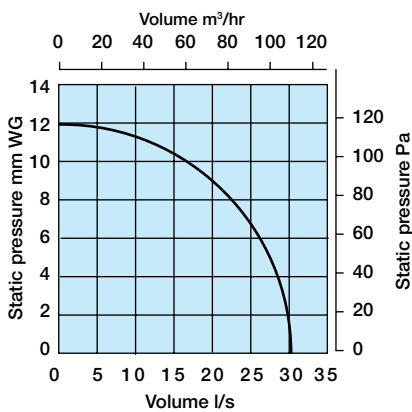

Packaging

CFD200/220 Series in outers of 5 measuring 200mm x 300mm x 240mm - weight 8kgs SCF200 Series in outers of 5. For packaging dimensions, please contact our technical department.

Electrical

220-240V - AC. 50Hz . Single phase consuming 20W on the CFD200/220 and SCF200.

All wiring must comply with the current IEE regulations. A double pole isolating switch, having a contact separation of at least 3mm in all poles, must be used with a 3 amp fuse fitted.

Additional Data

CFD200/220 SCF200
 Maximum pressure 120p.a.
 Fan speed: 1400 r.p.m.
 Sound volume: 45.0dB(A)
 Maximum operating temperature: 40°C