

MANHR200



Features & Benefits

- Single room heat recovery ventilation unit for kitchens/utilities room.
- Meets building regulations for kitchens and utility rooms for system 1 intermittent extract and for constant ventilation as per system 4 requirement.
- 3 speed motor.
- Integral washable filter.
- Up to 75% heat recovery.
- Saves energy - controls condensation.
- Extremely quiet.

Technical Details

Model No.

Product type

MANHR200WK

Std Kitchen Heat Recovery Unit

MANHR200CON

Electronic Controller*

Performance

	Speed 1	Speed 2	Speed 3
Extract Performance l/s (m ³ /hr)	16 (60)	30 (110)	61 (220)
Intake Performance l/s (m ³ /hr)	13 (50)	27 (100)	55 (200)
Watts	25	60	140
% Heat Recovery	75	70	65
Sound dB(A) at 3m	19	33	46

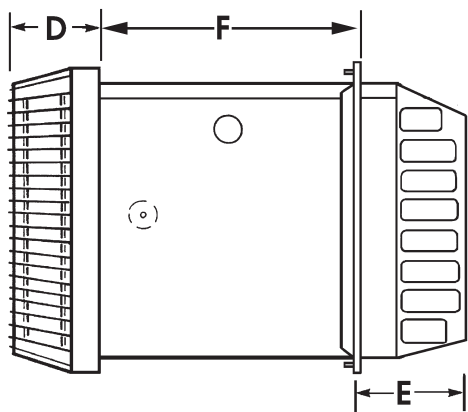
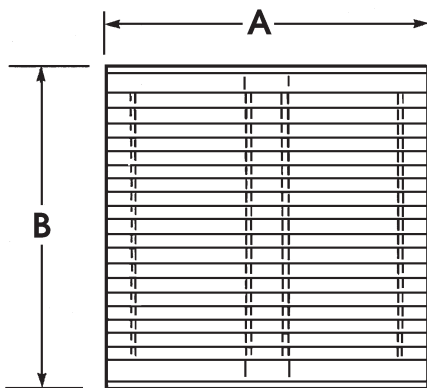

Dimensions:

A	B	C	D	E	F	Weight
270	270	245	85	68mn	335max	9.7kg

ERP SEC Class C