

MANHR200V



Features & Benefits

- Powered heat recovery module for smaller commercial applications.
- Up to 70% heat recovery.
- With 150mm duct connection.
- Extremely quiet on low speeds.
- Low power consumption.
- Washable heat exchanger.
- Pre-wired to a flexible cable.

Technical Details

Model No. Product type

MANHR200V	Heat Recovery Unit
MANHR150VA	150VA Transformer/ Speed Controller*

Performance

Motor speed	1	2	3	4	5
Voltage	100	120	140	160	240
Watts	30.0	40.0	51.5	60.0	110.0
Volume l/s (m ³ /hr) (FID)					
Supply	28(102)	38(138)	48(174)	56(201)	70(253)
Extract	37(139)	52(187)	67(241)	79(286)	103(371)

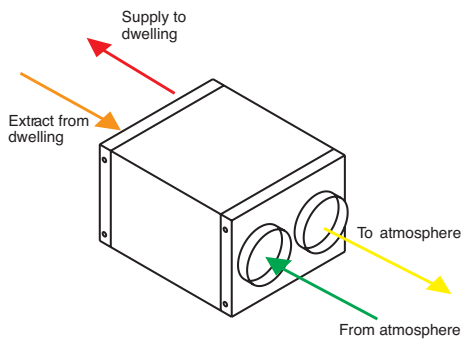

Dimensions

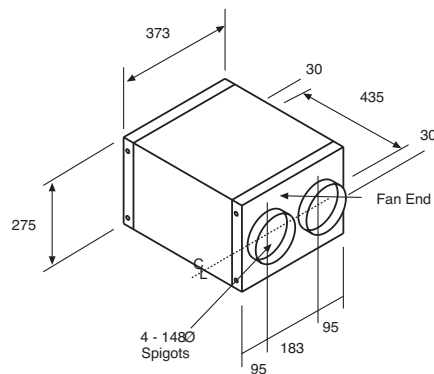

*For maximum controllability use this controller

ERP SEC Class C